

Rasonic
樂信牌

RSS-B12

迷你陶瓷燉盅 Mini Ceramic Stewing Mug

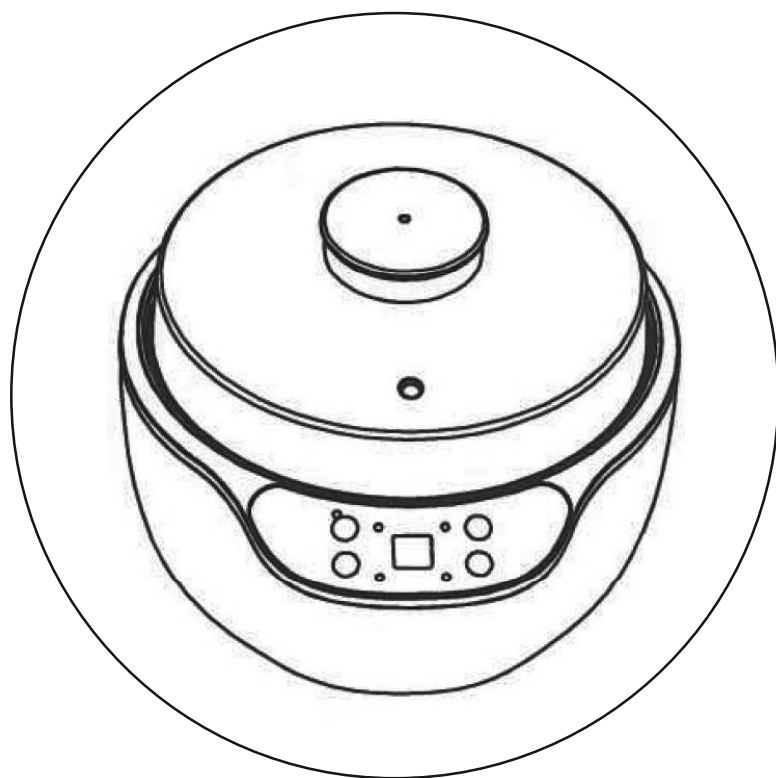

僅適用於家庭使用
For household use only

使用說明書

OPERATION MANUAL

- 在使用本產品前，請仔細閱讀本說明書，閱讀後小心收藏，以備日後查閱。
- Please read the operation manual carefully before using. Keep it in a safe place for future reference.
- 本說明書中的圖示可能有與實物不同的地方，僅供參考。
- Some figures in this manual may not match with the real object, just for reference only.

Instructions for use

非常感謝您選購樂信牌迷你陶瓷燉盅，使用前請先詳細閱讀本說明書，並保存以備日後參考。

目錄

1. 安全注意事項
2. 清潔及保存注意事項
3. 產品規格
4. 控制面板及產品結構
5. 使用方法
6. 故障排除
7. 特別聲明
8. 售後服務

1. 安全注意事項

使用本產品時，必須遵守下列安全措施：

1.1 使用前

1. 仔細閱讀本說明書，不遵循或忽視這些安全注意事項，有可能導致火災、觸電或個人傷害。
2. 將所有包裝物料全部取出並棄掉，以免兒童當作玩具造成危險。
3. 檢查本地電壓是否與產品額定電壓相符，將插頭插入合適的插座上。切勿與其他高功率的電器共用同一插座，以免電力負荷過重。同時，插座亦必須接駁地線。
4. 接駁電源前，須確保機體表面及插頭已充分擦乾，以免造成危險。

1.2 使用時

1. 切勿讓本產品在無人看管或注水格沒有水的情況下運作。
2. 切勿直接於注水格(發熱盤)內煮食。
3. 切勿在以下環境使用本產品：
 - 潮濕或接近水源的環境；
 - 靠近熱源及火源(如焗爐及電磁爐等)；
 - 不平穩或承托力不足的表面上；
 - 易燃物料或不耐熱物品附近(如地毯、塑膠枱布、窗簾及毛巾等)。
4. 注水格內必須預留足夠空間容納蒸氣及氣泡，以防滿溢。如注水太多或超出“最高水位”線，有可能造成溢出及其他危險。
5. 使用過程中或會有水點由上蓋邊沿濺出，切勿將本產品置於其他電器或電源拖板附近使用，以免引致火災、觸電或個人傷害。
6. 確保上蓋已完全關上，以防止水濺出或大量蒸氣噴出，或導致產品不能正常運作及產生危險。
7. **警告！** 在使用過程中或剛沸騰後，切勿將手、面或身體靠近上蓋蒸氣孔或觸摸主機。注意高溫蒸氣，避免造成燙傷。
8. 盡量避免於運作中途打開上蓋，否則沸騰的水會濺出引致燙傷。如需打開上蓋，建議先按【功能/取消】鍵取消有關加熱功能或關掉產品。打開時，小心蒸氣孔及上蓋有倒汗水滴落。
9. 完成烹調後，上蓋會有水珠(倒汗水)凝聚，此乃正常現象。避免凝聚水珠從上蓋或焗盅掉落到控制面板或電線位置，取出食物時，必先關掉產品及拔掉電源插頭，靜候數分鐘後再打開上蓋，避免被蒸氣燙傷。為安全著想，可使用隔熱手套。
10. 操作時，如需打開上蓋檢查食物，建議使用長把手的工具，亦避免將機體貼靠牆壁或傢具使用。
11. 當注水格沒有水時，切勿啟動本產品。若出現乾燒情況，請加水入注水格或拔出電源插頭。

12. 運作過程中，切勿移動或搖晃本產品，有可能引致大量蒸氣噴出，造成燙傷或其他危險。
13. 使用時，切勿用任何物件覆蓋本產品表面或遮擋蒸氣孔，以免造成產品故障、變形或變色。

1.3 使用後

1. 應先拔出電源插頭，待本產品冷卻後才進行移動清潔，或維修。
2. 烹調時及剛完成烹調後，切勿立即接觸本產品或其發熱盤，避免被餘熱灼傷。
3. 切勿將機身、電源線或插頭浸入水中，或被水濺濕，以免影響本產品的安全性能及可能構成觸電危險。使用前，必須確保插頭已完全擦乾。
4. 使用後或長期不使用時，請拔下插頭，以免因絕緣老化而引致漏電及觸電危險。切勿以濕手接觸、插上或拔除插頭，否則有可能引致觸電。

1.4 安全注意事項

1. 本產品設有防乾燒功能。在沒有盛水情況下運作，如機內溫度到達或超出保護值，本產品會停止運作及顯示錯誤代碼。若產品曾乾燒，先關掉產品及拔掉電源插頭，待其完全冷卻後才可再次使用。**警告！**防乾燒功能屬安全保護裝置，切勿依賴此功能關機。
2. 切勿使用外置計時器或遙控系統操作本產品，以防短路及自燃等危險。
3. 切勿使燉盅承受太大的溫度變化(例如：用明火加熱燉盅或將灼熱的燉盅放在雲石面上或冷水中)，否則可導致燉盅因冷縮熱脹而爆裂。
4. 切勿使用本產品烹煮酸或鹼類食物，以免腐蝕產品的燉盅或發熱盤表面。
5. 燉盅屬易碎物品，必須小心使用，避免碰撞或從高處跌落而造成損毀。
6. 若有兒童在旁，須加倍小心使用本產品及看管兒童，以確保他們不會把本產品當作玩具。切勿讓兒童單獨使用、清潔及進行保養，並將本產品及其電線置於遠離他們可能觸及的地方。
7. 小心使用電源線，不可在電源線上放置重物或夾住電源線；不可改裝或用力拉扯或扭曲電源線；在拔出或插入插頭時，應手握穩插頭，並確保將電源線與插座接駁良好。否則可能會引致危險。
8. 切勿在電源線纏結的情況下使用本產品，或將電源線懸掛在桌子、櫥櫃的邊緣或讓它接觸發熱的表面，否則會加快電源線的損耗。
9. 經常清理插頭上的塵埃，保持本產品清潔及不沾油污，特別是插頭的鐵片位置，以免引起火災的發生。
10. 切勿將本產品用於建議烹飪以外的其他用途。(否則，本產品有可能發生故障或危險。)
11. 本產品可供年齡在8歲或以上的兒童及體質、感覺或智力有障礙人士或缺乏經驗和相關知識的人士使用，但他們必須接受負責安全人士的監督或指導如何安全地使用產品和理解所涉及的危險。

12. 本產品僅供家用或在類似環境使用，如：商店內部、辦事處以及其他工作環境的員工廚房區域或類型的環境，切勿於戶外使用。
13. 經常檢查產品、燉盅、電源線及插頭。如發現任何損毀，或曾經跌落，為避免危險，應立即停止使用，並聯絡信興電器服務中心有限公司進行檢查及維修。
14. 必須使用生產商提供的原裝配件，切勿擅自改裝產品或使用非生產商提供的零件進行修理，否則，可造成危險及維修保養無效。本公司將不會承擔任何損壞的維修責任及賠償。
15. 遵從安全守則及避免釀成意外，如需要維修本產品，請攜同本產品、保修卡(印在包裝盒，**必須剪下保留**)及收據到信興電器服務中心有限公司，地址印於本說明書的背頁或致電熱線查詢：2406 5666。

2. 清潔及保存注意事項

1. 清潔前，必須拔除電源插頭，並待產品完全冷卻。
2. 陶瓷燉盅是易碎物品，使用及清洗時，請小心輕放，避免碰撞或讓陶瓷燉盅經常處於高溫狀態。
3. 清洗燉盅時，可用溫水及少量中性清潔劑清洗。切勿使用有毒或含腐蝕性的清潔劑進行清潔。
4. 切勿用水直接清洗主機外殼，亦避免讓液體流入本產品，以免造成故障及危險。
5. 如欲清除食物殘存氣味，可注水入燉盅及注水格，啟動產品將水煮沸，然後將水倒掉，待冷卻後再用溫水清洗。
6. 使用數次後，發熱盤位置或會出現乳白色、啡色或黑色的圓點，這是由於水中含有礦物質。礦物經過加熱轉化成化合物，然後沉澱形成水垢。水的硬度愈高，水垢囤積速度愈快，此乃正常現象，不影響使用。
7. 如須清除注水格內的水垢，可參考以下方法處理：
 - 於注水格內注入清水(建議加入250毫升清水)；
 - 將半個切片檸檬放入注水格內(或按每升水20克檸檬酸比例加入)；
 - 選擇“蒸”(Steam)功能將水加熱至沸騰，然後按【功能／取消】鍵停止運作及靜候約20分鐘。將注水格內的水全部倒掉，然後用海綿或軟毛刷擦洗發熱盤位置。完成後，用水沖洗過淨。

注意！如發現有檸檬酸味殘留，可再次注水加熱至沸騰，然後將水倒掉即可。
8. 切勿用電油、去污粉或粗硬的潔具(如鋼絲刷)清潔。
9. 如發現注水格、機身或上蓋有污穢，可用濕布抹淨，再抹乾。
10. 待產品完全冷卻及清洗後，才能存放入紙箱，然後儲存在乾爽的環境中。切勿用電源線纏繞在本產品四周或壓住電源線，避免做成電源線損壞。

3. 產品規格

| | |
|-------------|--------------------|
| 型號 | RSS-B12 |
| 額定電壓 | 220-240伏特~ 50-60赫茲 |
| 額定功率 | 200瓦 |
| 陶瓷燉盅容量 | 1.2升 |
| 淨重 | 約2.06公斤 |
| 產品尺寸(闊x深x高) | 218 x 247 x 178毫米 |

4. 控制面板及產品結構

4.1 控制面板

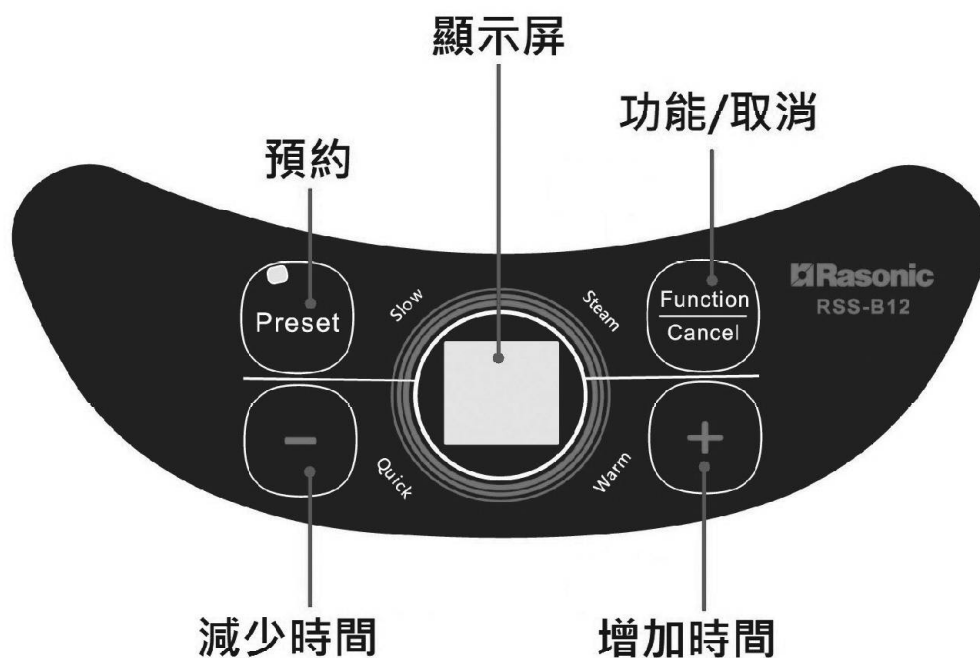

4.2 產品結構

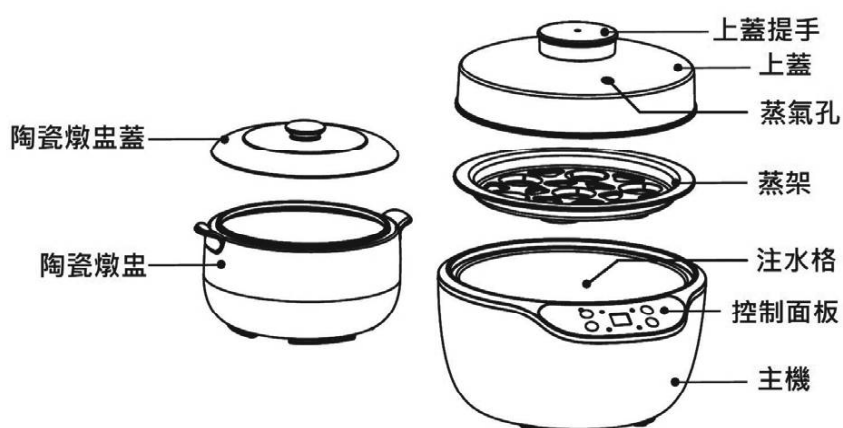

功能運作時間表

| 功能名稱 | 預設運作時間 (小時) | 可調校時間範圍 (小時) | 每次調校 增加／減少時間 (小時) |
|------------|----------------|-----------------|-------------------------|
| 快燉(Quick) | 3.0 | 0.5 – 5.0 | 0.5 |
| 慢燉(Slow) | 4.0 | 0.5 – 7.0 | |
| 蒸(Steam) | 0.3 | 0.3 – 2.1 | 0.3 |
| 預約(Preset) | 2.0 | 0.5 – 9.5 | 0.5 |
| 保溫(Warm) | 不適用 | | |

*** 以上功能的運作時間中，每0.1小時表示6分鐘。

5. 使用方法

5.1 首次使用

1. 初次使用時，產品或會有新包裝物料的味道，正乃正常現象。經數次使用後，味道會逐漸消失。
2. 確保電源插頭未被接上，並根據不同的情況，按照「**章節5.2預備工作**」及「**章節5.3操作說明**」使用本產品。

5.2 預備工作

注意！使用前，先用水徹底清洗陶瓷燉盅。

注意！注水入注水格時，不可超過注水格的“最高水位”線；應使用蒸餾水或普通清水，切忌使用礦泉水，以免加快水垢形成。

燉煮功能 [“快燉”(Quick)及“慢燉”(Slow)]

1. 將適量的食材和水加入陶瓷燉盅，蓋好陶瓷燉盅蓋；
2. 將陶瓷燉盅放入主機；
3. 注水入注水格至“最高水位”線，最後蓋上上蓋。

*** **注意！**為避免倒汗水滴濕電源插頭，建議打開上蓋時垂直向上提起，然後倒置上蓋讓倒汗水倒流入內，藉此避免水滴掉落控制面板或電源線上。

蒸煮功能 [“蒸”(Steam)]

1. 先注水入注水格(建議加入500毫升清水，水面剛覆蓋底部凸台為佳)；
2. 將蒸架置於主機，然後將需要加熱的食物置於蒸架上(如食材於蒸煮過程會出水，請以容器盛載)；
3. 最後蓋上上蓋。

*** **注意！**使用過程中會產生大量蒸氣及倒汗水，或會影響烹調效果。如有需要，可用耐高溫保鮮紙包裹容器，以防倒汗水滴入食物中。

5.3 操作說明

1. 接上電源後，產品會發出“Di”聲，顯示屏顯示“—”，表示產品進入待機模式。按【功能／取消】鍵選擇所需功能，烹調功能會以“快燉”(Quick) -> “慢燉”(Slow) -> “蒸”(Steam) -> “保溫”(Warm) -> “待機模式”(—)順序循環顯示。對應功能指示燈會閃動，顯示屏顯示該烹調功能的預設運作時間。
2. 選定烹調功能後，按【+】及【-】鍵調整運作時間。完成後，等候10秒以確認有關設定，對應功能指示燈會由閃動轉為長亮，產品便會開始運作。
3. 完成烹調後，產品會發出“Di Di Di Di”聲，“EE”會於顯示屏閃動，並會於1分鐘後自動進入保溫模式。此時，“EE”會由閃動轉為長亮。
4. 如用戶不需保溫功能，可於保溫期間按【功能／取消】鍵自行取消，顯示屏顯示“—”，產品會返回待機模式。
5. 建議等待約5分鐘方可打開上蓋及取出食物，避免被濺出的水燙傷。

注意！如運作過程中或保溫過程中水份完全蒸發，產品會發出“Di Di Di Di”聲，“E0”會於顯示屏閃動，產品將暫停運作，待產品自然冷卻或加水直至溫度低於保護值，產品才會恢復待機狀態，如有需要請重新選擇功能繼續使用本產品。

5.4 預約功能(預約產品開始運作時間)

根據使用方法，按「**章節5.2預備工作**」的指示放置清水及食材，然後按以下步驟設定理想的預約時間。

注意！容易變質的食物不建議設定過長預約時間，避免食材變質。

例子：預約6小時後，開始5小時“慢燉”(Slow)功能

- 接上電源後，顯示屏顯示“—”，產品進入待機模式；
- 按【預約】鍵，預約指示燈閃動，顯示屏顯示預設時間“2.0”(2小時)。按【+】鍵調校預約時間至“6.0”(6小時)。
- 按【功能／取消】鍵選擇“慢燉”(Slow)功能，對應功能指示燈閃動，預約指示燈亦會亮起，顯示屏顯示“慢燉”(Slow)預設運作時間“4.0”(4小時)。按【+】鍵調校烹調時間至“5.0”(5小時)。
- 完成後，等候10秒以確認有關設定，預約功能開始運作。
- 約6小時後，“慢燉”(Slow)功能會開始運作5小時，直至烹調程序完成。完成後，產品會發出“Di Di Di Di”聲，“EE”會於顯示屏閃動，並會於1分鐘後自動進入保溫模式。此時，“EE”會由閃動轉為長亮。
- 保溫功能會一直運作，直至注水格的水完全蒸發。(具體運作可參考「**章節5.5保溫功能**」)

5.5 保溫功能

烹調完成後，產品將自動進入保溫狀態。此功能並沒有預定的完結時間，產品會一直保溫直至注水格的水份完成蒸發。屆時，產品會發出“Di Di Di Di”聲，“E0”會於顯示屏閃動，並會於40秒後轉為關機狀態。

如需獨立開啟保溫模式，用戶可按【功能／取消】鍵選擇“保溫”(Warm)功能，對應功能指示燈閃動，“EE”會於顯示屏長亮。等候10秒以確認有關設定，產品會自動進入保溫模式。

運作過程中，如須取消保溫模式，可按【功能／取消】鍵取消，顯示屏顯示“—”，產品會返回待機模式，用戶可拔出電源插頭。

注意！切勿將易變質的食物保溫過長的時間，否則可能導致食物變質。

5.6 取消功能

運作過程中，如需取消有關烹調功能，用戶可於選定烹調功能後(即對應功能指示燈由閃動轉為長亮後)，按【功能／取消】鍵，顯示屏顯示“—”，有關烹調功能將會取消，產品會返回待機狀態。

6. 故障排除

如出現以下異常情況或故障，應立即停止使用本產品，並將本產品送往信興電器服務中心有限公司進行檢查及維修。

1. 電源線或電源插頭異常發熱。
2. 稍微屈曲電源線，產品即時出現斷續通電的情況。
3. 產品異常發熱、釋出燒焦味道或冒煙。
4. 當接觸產品的外殼，有感覺到觸電情況。
5. 有部分時間無法自行斷電。
6. 產品出現漏水情況。

7. 特別聲明

1. 本資料上所有內容經過核對，如有任何印刷及內容上的誤解，本公司將保留解釋權。
2. 本產品若有技術改進，會編進新版說明書中，恕不另行通知；產品外觀、顏色如有改動，則以製造商生產資料為準。
3. 如本資料之中英文版本有差異時，應以中文版為準。
4. 使用說明書的電子副本可以通過電子郵件發送致客戶，如有需要，可致電信興電工工程有限公司：28612767。

8. 售後服務

1. 由購買收據起之一年保修期內，經信興電器服務中心有限公司之服務人員證實產品故障屬正常使用發生者，本公司將提供免費維修或更換零件服務。經更換之任何損壞／毀零件，將屬本公司所有。保修範圍不包括修理或更換損耗性零件和配件(包括陶瓷燉盅、陶瓷燉盅蓋、蒸架、上蓋、控制面板貼紙及電源線等)。如使用不當，或作(半)商業用途，或未依照說明書使用，保修服務將無效，本公司將不會承擔任何損壞的維修及賠償。
2. 用戶必須於維修時出示購買／換購收據及蓋有銷售點／換購中心印章的**產品保修紀錄卡(印在包裝盒，必須剪下保留)**，如有任何疑問，請致電信興電器服務中心有限公司熱線查詢：24065666。

Thank you for choosing Rasonic Mini Ceramic Stewing Mug. Please read the operation manual carefully before use and keep it for your future reference.

Table of Content

1. Important Safeguards
2. Cleaning and Storage Guideline
3. Product Specifications
4. Control Panel and Product Structure
5. Operation Instructions
6. Troubleshooting and Treatment
7. Special Avowal
8. After Sales Service

1. Important Safeguards

When using the appliance, make sure to follow the below safety precautions:

1.1 Before use

1. Read the operation manual before using the appliance. Failure or negligence in following these safety precautions could cause fire, electrical shock or injury.
2. Remove and discard all packing materials of the appliance. Make sure children do not play with them to avoid any danger.
3. Before connecting to the electricity, check if the rated voltage on the appliance corresponds to the local voltage. To avoid overload, do not connect the appliance in the same power socket with other high power consumption appliances. Make sure the appliance is connected to power socket with grounding.
4. To avoid any hazard, make sure the plug is dry before use.

1.2 In operation

1. Never leave the appliance unattended when in use or operate without water.
2. Do not cook inside the water tank (heating plate) directly.
3. Do not operate the appliance in the following places:
 - Humid environment or near water sources
 - Near heat and fire sources (such as electric oven and induction cooker etc.)
 - Unstable and insufficient support surface
 - Near inflammable or non-resistant to heat objects (e.g. carpet, plastic, table cloth, curtain and towel etc.)
4. Sufficient room must be reserved for steam or air bubbles generated, and amount of water should not exceed the maximum water level “最高水位” of the water tank. Otherwise, water and steam may spill out during operation and cause dangers.
5. Water may splash out from the edge of lid during operation. To avoid fire, electrical shock or injury, do not operate the appliance near the other appliances or electric socket extension.

6. Make sure the lid is closed tightly to prevent water from splashing out or steam discharging; otherwise, the appliance may not function properly or cause hazards.
7. **WARNING!** Do not open the lid during operation or right after use, as massive steam will come out from the steam hole, only by doing so can prevent steam burn.
8. Do not open the lid during operation, otherwise boiled water may spill out and cause burns. If necessary, press [Function/Cancel] button to switch off the appliance before open the lid. Be careful of the hot steam and droplets when open the lid.
9. After cooking, a lot of vapour and water droplets will remain inside the body and lid, which is a normal phenomenon. To avoid burns, switch off the appliance and unplug the power, wait for a while before opening the lid to avoid burn by residue heat. Open the lid carefully to avoid condensed water droplets from the lid onto the control panel or power cord. To avoid scalding by hot steam, use oven mitts to pick up the food from the appliance.
10. Always use kitchen utensils with long handles when checking the food inside. Beware of hot steam, do not operate the appliance next to wall or furniture.
11. Do not switch on the appliance when there is no water in the water tank. If over heating occurred, add water into the water tank or unplug the power.
12. Do not open the lid, move or shake the appliance during operation as to avoid massive steam emission resulting in burns or other hazards.
13. To avoid appliance malfunction, deformation or discoloration, do not cover the appliance or steam vent by any object when using the appliance.

1.3 After use

1. Unplug the appliance from the socket and let the appliance cool down before moving, cleaning and repairing.
2. To avoid getting burned, never touch the product enclosure and heating plate which are subject to residual heat right after use.

3. To prevent electric shock and fire, never immerse the main body, power cord or plug in water or let them wet. Make sure the plug is dry before use.
4. Disconnect the power plug when the appliance not in use for long time, preventing electric leakage and electric shock due to insulation degeneration. Do not touch, plug or unplug the appliance by wet hands which can result in electric shock.

1.4 Beware of the following

1. The appliance equipped with boil-dry protection system. If water inside the pot completely evaporated or temperature exceeds the protection level, the operation will stop while error code will show on display. If the appliance was boiled dry once, switch off and lift the main body from the power base and cool down completely before reuse. **CAUTION!** Boil-dry protection is the device for protection. Do not rely on this function to switch off the appliance.
2. The appliance is not intended to be operated by means of an external timer or separated remote control system, as to prevent short-circuit or other flammable hazards.
3. Do not let the ceramic mug withstand big temperature difference. (For example: Heat the ceramic mug with fire or put the hot ceramic mug on a marble surface or into cold water), otherwise the mug may crack because of thermal expansion and contraction.
4. To prevent water tank and ceramic mug corrosion, avoid cooking any substance that is acidic or alkaline.
5. The ceramic mug is a kind of fragile ware. Use it carefully. Do not hit the mug or drop it from a high place to avoid damage.
6. Great care is necessary in using the appliance, especially near children. Children should be supervised to ensure that they do not play with the appliance. Also, children without adult supervision should not operate the appliance. Keep them away from the appliance and its power cord.

7. Handle the power cord with care. Do not place heavy objects on the power cord. Never clip, modify, stretch or twist the power cord. Do not grasp the power cord but the plug itself when plug in or unplug the appliance. Ensure that the power plug fits all the way into the appliance socket, fail to do it may cause electric hazard.
8. Do not operate the appliance when the power cord is tangle or hang over the edge of a table, countertop or let it touch any hot surface. It may cause power cord damage.
9. Always wipe off any dust from the power plug and clean the appliance, make sure it is not oily, especially on the pins such to prevent fire from happening.
10. Do not use the appliance for purposes other than cooking. (If the appliance is not used for cooking, it may cause malfunction and hazard.)
11. The appliance can be used by children aged from 8 years and above and persons with reduced physical, sensory or mental capabilities, or lack of experience and knowledge, if they have given supervision or instruction concerning use of the appliance in a safe way and understand the hazards involved.
12. The appliance is intended to be used in household or similar applications such as staff kitchen areas in shops, offices and other working environments. Do not use it outdoors.
13. Always check the condition of the appliance, ceramic mug, power cord and plug. To avoid hazard, stop using the appliance immediately if the appliance is damaged or dropped. Contact Shun Hing Electric Service Centre Limited for checking and repairing.
14. Do not use, replace or assembly any parts which is not produced under authorization, otherwise, the warranty becomes invalid and our company will refuse any liability and repairing cost for the damage caused.
15. To comply with safety regulations and avoid hazards, if repair is needed, present the official invoice, warranty card (**printed on the gift box and must be saved it for future reference**) with the appliance for repair service and contact Shun Hing Electric Service Centre Limited hotline at 2406 5666. Address can be found at the back page of the manual.

2. Cleaning and Storage Guideline

1. Before cleaning, unplug the appliance and let it cool down completely.
2. Ceramic mug is a kind of fragile ware, handle with care and do not place in high temperature environment for a long time.
3. Use warm water together with mild detergent to clean the ceramic mug. Never use poisonous or corrosive detergent for cleaning.
4. To avoid malfunction and dangers, do not clean the main body with water directly or let water penetrate inside the main body.
5. To remove the odor, add some water to the ceramic mug and the water tank, turn on the appliance until water boiled. Pour out the water and wait until the appliance cool down completely. Then wash it with warm water.
6. Due to the minerals in water, color scale will be found on the heating plate after heating. The harder the water, the quicker the scale will be formed. It is a normal phenomenon and will not affect the operation.
7. To remove the water scale, follow the below instructions:
 - Fill water into the water tank (250ml of water recommended)
 - Put halved sliced lemon in the water tank (Or, follow the ratio to add 20g citric acid per 1L water).
 - Operate "Steam" function until the water boiled. Press the [Function/Cancel] key to stop the operation, wait and pour out all water after around 20 minutes. Then clean the heating plate with a sponge or soft brush, and rinse by water at the end.

NOTICE! To remove the remaining smell of citric acid, boil water again and pour it out afterward.
8. Never clean the appliance by using gasoline, cleanser or harsh cleaning tools (e.g. metal brush).
9. If dirt is attached on the water tank, main body or lid, use a damp cloth to clean and wipe them dry.
10. Always let the appliance cool down completely before storage. Put it in a paper box and store in a dry environment. Never wrap the power cord tightly around the appliance or put pressure on it to avoid the power cord damage.

3. Product Specifications

| | |
|--------------------------|--------------------|
| Model No. | RSS-B12 |
| Rated Voltage | 220-240V~ 50-60Hz |
| Rated Power | 200W |
| Ceramic Mug Capacity | 1.2 L |
| Net Weight | Approx. 2.06 kg |
| Product size (W x D x H) | 218 x 247 x 178 mm |

4. Control Panel and Product Structure

4.1 Control Panel

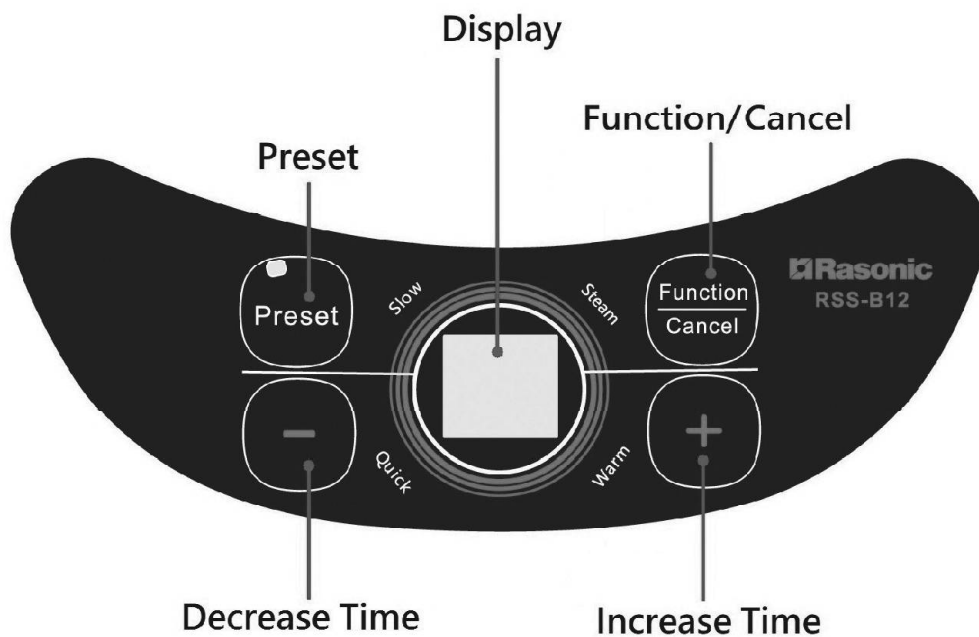

4.2 Product Structure

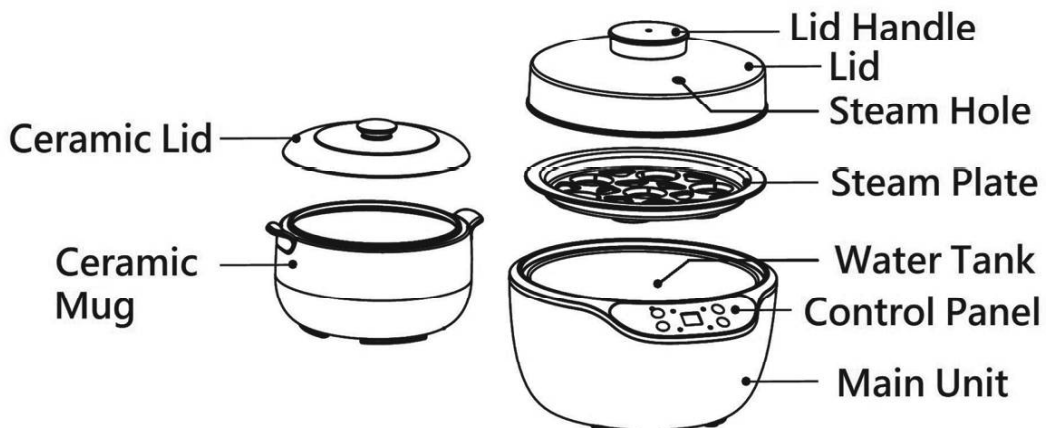

Operation Time Table

| Function | Preset operation time (Hour) | Adjustable operation time (Hour) | Time interval increase or decrease per press (Hour) |
|--------------|------------------------------|----------------------------------|---|
| "Quick" Stew | 3.0 | 0.5 – 5.0 | 0.5 |
| "Slow" Stew | 4.0 | 0.5 – 7.0 | |
| "Steam" | 0.3 | 0.3 – 2.1 | 0.3 |
| "Preset" | 2.0 | 0.5 – 9.5 | 0.5 |
| Keep "Warm" | Not applicable | | |

*** Each 0.1 hour of operation time represents 6 minutes.

5. Operation Instructions

5.1 Before First Use

1. When the first time of use, it may have smell due to the new packing. It is a normal phenomenon where the smell will gradually disappear with time.
2. Make sure the appliance is not plugged, and depend on the cooking functions, follow the instruction stated in "Chapter 5.2 Preparation" and "Chapter 5.3 Function Selection" to operation the appliance.

5.2 Preparation

CAUTION! Clean the ceramic mug by water before using.

CAUTION! Do not exceed the maximum water level "最高水位" of the water tank when filling water. Only use distilled water or tap water, never use mineral water as it will fasten the formation of scale.

Stewing functions ("Quick" Stew & "Slow" Stew)

1. Put appropriate amount of ingredients and water into the ceramic mug supplied, and close the ceramic lid.
2. Place the ceramic mug into the main unit.
3. Add water to the maximum water level "最高水位" of the water tank, and close the lid finally.

*** **NOTE!** To avoid the power plug from getting wet by the water droplets, lift the lid vertical when open. To avoid water droplets dripping off onto the power cord and control panel, upside down the lid when lifting and let water droplets backflow to the lid.

Steaming function ("Steam")

1. Pour water into the water tank (Water added just cover the saddle-platform is suggested, approx. 500ml).
2. Put the steam plate inside the main body. Place the food directly on the plate and cover the lid (If the ingredients will generate juice after heating, make use of a container).
3. Close the lid finally.

*** **ATTENTION!** During operation, a lot of vapor and water droplets will be generated; to avoid affecting the cooking result by water dropping onto the food, make use of heat-resistant cling wrap to seal the container.

5.3 Function Selection

1. After connecting to the electricity, a "Di" sound will be heard. The display will show "--" representing the appliance is in standby mode. Press [Function/Cancel] key to select desired function where "Quick" -> "Slow" -> "Steam" -> "Warm" -> Standby (—) mode will show in order. Function indicators will flash accordingly while default operation time will show on the display.
2. After choosing the cooking function, press the [+] and [-] keys to adjust desired operation time. Once finish, wait for about 10 seconds to confirm. Related function indicator will change from flash to light up and the operation will start.
3. When the operation completed, "Di Di Di Di" sounds will be heard. "EE" will flash on display and the appliance will switch to keep warm mode after about 1 minute. "EE" on the display will change from flash to light up accordingly.
4. If no keep warm function is needed, press the [Function/Cancel] key to cancel during warm keeping. "--" will show on display and the appliance will change to standby mode.
5. Suggested to wait for about 5 minutes before opening the lid and taking out the food, as it can avoid burns by water spilling.

CAUTION! The appliance will automatically turn off if water inside the water tank evaporated during operation or warm keeping. The appliance will emit "Di Di Di Di" sounds and "EO" will flash on display at the time when the operation suspended. The appliance will return to standby mode if refill water or let it cool down naturally such that temperature drops below protection value. Reuse the appliance by selecting a cooking function again.

5.4 Preset function (The time to start the operation)

Follow the procedures described in "Chapter 5.2 Preparation", place the ingredients and water into the ceramic mug, and follow the steps below to preset the cooking function.

NOTE! Perishable foods are not recommended for long preset time as to avoid deterioration.

For example: Preset 6 hours "Slow" function for 5 hours.

- After connecting to the electricity, "--" will show on the display representing that the appliance is in standby mode.
- Press the [Preset] key once, the preset indicator will flash and the default preset time "2.0" will show on display. Press the [+] key to adjust the time setting to "6.0" (6 hours).
- Press the [Function/Cancel] key to select the "Slow" function, corresponding indicator will flash and "Preset" indicator will light up. Display will show the default cooking time "4.0" (4 hours). Press the [+] key to adjust the cooking time setting to "5.0" (5 hours).
- Wait for about 10 seconds to confirm the setting and "Preset" function will start.
- After 6 hours elapsed, "Slow" function will start for 5 hours until the operation completed. "Di Di Di Di" sounds keep operating will be heard and "EE" will flash on display. The appliance will switch to keep warm mode after about 1 minute. "EE" on the display will change from flash to light up at the same time.
- Warm keeping will continue until water inside the water tank evaporated. Detailed information can be found in "Chapter 5.5 Keep Warm Function".

5.5 Keep Warm Function

The appliance will change to keep warm mode automatically after the operation completed. No defined operation time for warm keeping, so the appliance will turn off until the water inside the water tank evaporated. "D| D| D| D|" sounds will be heard and "E0" will be shown on display, the appliance will then turn off automatically after 40 seconds.

User can press the [Function/Cancel] key to select "Keep Warm" function, related indicator will flash, and "EE" will show on display. Keep warm function will start operating after 10 seconds.

If keep warm function is not necessary during operation, press the [Function/Cancel] key once, "--" will be shown on display representing the appliance is in standby mode. User can unplug the power now

ATTENTION! Do not warm perishable foods for too long, otherwise, it may generate odor and get deteriorated.

5.6 Cancel Function

To cancel a cooking function, user must press the [Function/Cancel] key after the confirmation (which means after the related indicator changing from flash to light up), the set cooking function will be cancelled. "--" will show on display and the appliance will return to standby mode.

6. Troubleshooting and Treatment

If the following situation happens, unplug the appliance immediately. Contact and report to Shun Hing Electric Service Centre Limited for checking and repairing.

1. If the power cord or power plug is abnormally hot.
2. If the electricity flows discontinuously when the power cord is bent.
3. If the appliance is abnormal hot or if you smell smoke or scorching.
4. If you get shocked when touching the appliance.
5. If the appliance sometimes does not turn off automatically.
6. If water is leaking out from the appliance.

7. Special Avowal

1. The content in the operation manual has been checked. Our company reserves the hermeneutic power to any printing errors or misunderstanding on the content.
2. If there are technical improvements on the appliance, the operation manual will be updated in new version without prior notice. The product appearance and specification are subject to the manufacturer information.
3. In case there is any inconsistency or conflict between the English versions and Chinese versions of the terms, the Chinese versions shall prevail.
4. E-copy of user manual can be sent by e-mail on request, please call Shun Hing Electric Works & Engineering Co., Ltd. at 2861 2767.

8. After Sales Service

1. For any defect, in the judgment of technician from Shun Hing Electric Service Centre Limited, caused under normal use, our company is responsible for repairing or replacing any parts of the said electrical appliance free of charge within one year guarantee period commencing from the date of purchase. Any defective part which has been replaced shall become our property. Warranty service does not cover the repair or replacement of consumable parts (including ceramic mug, ceramic lid, steam plate, lid, control panel sticker and power cord, etc.). If the appliance is used improperly, for commercial (or semi-commercial) use, or not following the instructions in the operation manual, the warranty becomes invalid and our company will refuse any liability and repairing cost for the damage caused.
2. User must present the official invoice/redemption voucher and the **product warranty card (printed on gift box, and must be saved it for future reference)** with the chop from sales point/redemption center for maintenance. For enquiries, please call Shun Hing Electric Service Centre Limited hotline at 2406 5666.



SHUN HING GROUP
信興集團
SINCE 1953

 **Rasonic 樂信牌**

信興電工工程有限公司

SHUN HING ELECTRIC WORKS AND ENGINEERING CO., LTD.

辦公室：香港九龍尖沙咀東部麼地道67號半島中心9樓

電話：2861 2767

圖文傳真：2865 6706

網址：<http://www.rasonic.com>

電郵：shew@shunhinggroup.com

Office: 9/F, Peninsula Centre, 67 Mody Road, Tsimshatsui East, Kowloon, Hong Kong

Tel: 2861 2767

Fax: 2865 6706

Website: <http://www.rasonic.com>

E-mail: shew@shunhinggroup.com

保養及維修 Maintenance and Repair Service:

信興電器服務中心有限公司

SHUN HING ELECTRIC SERVICE CENTRE LTD.

香港新界葵涌勝耀街2號信興中心11樓

服務熱線：2406 5666

傳真號碼：2408 0316

網址：<http://www.shesc.com/zh>

11/F, Shun Hing Centre, 2 Shing Yiu Street, Kwai Chung, N.T. HK

Service Hotline: 2406 5666

Fax No.: 2408 0316

Website: <http://www.shesc.com/en>

客戶服務中心：

香港新界葵涌勝耀街2號信興中心1樓

九龍尖沙咀東部麼地道67號半島中心B座9樓

香港天后琉璃街7號柏景中心22樓

澳門慕拉士大馬路193-199號南嶺工業大廈5樓1座

Customer Service Centre

1/F, Shun Hing Centre, 2 Shing Yiu Street, Kwai Chung, N.T.

9/F., Block B, Peninsula Centre, 67 Mody Road, Tsim Sha Tsui East, Kowloon

22/F, Parkview Centre, 7 Lau Li Street, Tin Hau, Hong Kong

Avenida de Venceslau de Morais, No. 193-199,5 andar - I, Edf. Industrial Nam Leng, Macau

有關最新之香港及澳門客戶服務中心資料，請參閱信興服務中心網址：<http://www.shesc.com/zh>

For the latest information of Hong Kong and Macau service center, please visit <http://www.shesc.com/en>